



## **GUIDELINES FOR PROMOTING TOURIST' SAFETY IN CHIANG MAI PROVINCE**

**Wu Yulai**

Email: [wuyulai168@gmail.com](mailto:wuyulai168@gmail.com)

**Asst. Prof. Dr. Srochinee Siri wattana**

Email: [Srochinee.si@ssru.ac.th](mailto:Srochinee.si@ssru.ac.th)

**Dr. Wannapreya Lohavattanakul**

Email: [wannapreya@pentinum.co.th](mailto:wannapreya@pentinum.co.th)

**Phra Suchin Panyasin**

Email: [Mongkon4289@gmail.com](mailto:Mongkon4289@gmail.com)

**Dr. Duangkamon Chantararatmanee**

Email: [Duangkamon.nok21@gmail.com](mailto:Duangkamon.nok21@gmail.com)

### **Abstract**

The tourists expect to be safe throughout the trip when they traveling to various places. Protecting, caring, assisting, and creating safety for tourists is very important. The objectives of this research were to: 1) study the level of tourism policy, tourism infrastructure, public participation, destination management, and tourist safety in Chiang Mai Province; 2) examine the influence of tourism policy, tourism infrastructure, public participation, and destination management on tourist safety Chiang Mai Province; and 3) propose a guideline for promoting tourist safety in Chiang Mai Province. This was a mixed-methods study. For quantitative research, the sample of 320 tourists in Chiang Mai Province was selected by using the multi-stage randomization technique. For the qualitative component, in-depth interviews were conducted with 16 key informants, comprising: 1) six public and private sector executives, 2) six tourism and service entrepreneurs and 3) four tourists in Chiang Mai Province.

The results indicated that: 1) tourism policy, tourism infrastructure, public participation, destination management, and tourist safety in Chiang Mai Province were at high levels; 2) tourism policy, tourism infrastructure, public participation, and destination management, have an overall influence on tourist safety in Chiang Mai Province at a statistically significant level of 0.05 with impact values of 0.87, 0.86, 0.70 and 0.36 respectively; and 3) a guideline for promoting tourist safety in Chiang Mai Province was as follows: (1) The government sector establishes concrete measures for tourist prevention, care, and assistance to create tourist safety; (2) government, private and public sectors encourage public involvement in tourist destination, fostering care and assistance for tourists; (3) Information on tourism destinations is sufficient and up-to-date; (4) tourism destinations have security systems and procedures in place to address incidents or emergency situations involving tourists; and (5) the entrepreneurs involved public transportation systems pay attention to quality,

standards, and tourist safety. Therefore, the government and private sector, the public sector, and stakeholders in tourism Chiang Mai Province must be more aware and pay more attention to tourist safety.

**Keywords:** Tourism Policy/ Tourism Infrastructure/ Public Participation / Destination Management/ Tourist Safety

## **Introduction**

The tourism industry is an important driver of each country's economic growth and development. In 2018, tourism was valued at US\$1,480 billion, becoming a huge industry in the world (Gossling, Scott & Hall, 2020). Asia has the second highest number of tourist arrivals for activities and tourism after Europe. In 2018, Thailand's total tourism revenue was 3.08 trillion baht, the 4th highest in the world. The COVID-19 pandemic has reduced the number of tourists. When the COVID-19 outbreak is controlled, As a result, the government has begun to relax various measures, allowing more travel. In the first four months of 2022, both Thai and foreign tourists traveled and generated revenue of approximately 240 billion baht for Thailand. The revenue is mainly generated from Thai tourists (Bank of Thailand, 2022). On June 1, 2022, Thailand fully opened to tourists. In January 2023, 2,088, 832 tourists arrived (Ministry of Tourism and Sports, 2023).

Tourist safety is important as reflected by the COVID-19 pandemic, which directly affects health safety and poses a danger to the lives of citizens and tourists. When countries fail to control the spread of the disease, tourists feel the health insecurity they may be incurring and do not travel (Caldeira, Seabra & AlAshry, 2022). Tourism safety is an important factor that plays a part in tourists' travel decisions. Whether tourists come to visit or repeat trips, It has to do with the security credibility established by each country's government (Ma, Chiu, Tian, Zhang & Guo, 2020). Public and private sector executives, as well as operators involved in the tourism industry, need to take steps to ensure the safety of tourists (Kaszas & Keller, 2022).

Chiang Mai is a province located in the northern part of Thailand, with cultural heritage sites, The weather is suitable and the tourist attractions are diverse, It has gained popularity and interest from Thai and foreign tourists. As a result, Chiang Mai receives a large number of tourists each year. In 2018, there were 2,650,835 tourists, including 1,837,775 Thai tourists and 813,081 foreign tourists (Chiang Mai Tourism Office, 2018). Tourists come to travel partly through word of mouth and travel experiences of friends or family members. However, tourists traveling to Chiang Mai are unsafe, such as scammers pretending to open pages as tourist attractions, Tricked into transferring money for accommodation or homestay, This causes damage to both real entrepreneurs and customers. Therefore, the Chiang Mai Provincial Tourism Office has established a tourist assistance center to facilitate and ensure the safety of tourists coming to Chiang Mai during the peak season (Darunee Meksuwan, 2023). Or a road accident with a tourist on the 10th. November 2023 resulted in the immediate death of two tourists, a Dutch man and a French woman, and 10 others were injured (Manager Online, 2023). The incidents reflect the insecurity of tourists that

can occur at any time. Therefore, awareness and prioritization of tourist safety requires the cooperation of the government, private sector and the public sector of Chiang Mai.

### **Research Objectives**

1. To study the level of tourism policy, tourism infrastructure, public participation, destination management and the safety of tourists in Chiang Mai.
2. To study the influence of tourism policy, tourism infrastructure, public participation and destination management that affects the safety of tourists in Chiang Mai
3. To present guidelines for promoting tourist safety in Chiang Mai.

### **Research Hypothesis**

1. Tourism Policy influences the safety of tourists in Chiang Mai
2. Tourism infrastructure influences tourist safety in Chiang Mai
3. Public participation influences the safety of tourists in Chiang Mai
4. Destination management influences the safety of tourists in Chiang Mai

### **Literature Review**

#### **Tourists Safety**

Tourist safety refers to the fact that tourists are protected from incidents that tourists do not intend to occur, and incidents that others do deliberately to tourists (Payam, 2016). Tourist safety means that tourists are protected from harm or risk to health, life, Housing conditions, goods, covering where an agency or individual has planned or prevented the occurrence of harm, and a variety of crimes or threats (Radovic &Arabska, 2016). And tourists are not affected or harmed by crime, terrorism, unsafe food, Health and disaster impacts (Tan, Chong & Ho, 2017). There are three types of tourism risk factors : (1) Macro risk factors are risk factors that occur at the national level that require strategic management to address them, such as latent populations, Poverty and poor quality infrastructure, etc (2) situational risk factors such as tourist density, tourist behavior, Areas that are difficult to control, etc and (3) locational risk factors such as lighting, low security measures, There are not enough officers, and there is a lack of police surveillance, etc. (Vuuren, 2016). Tourists value safety from crime and theft that affects life and property (Mawby et al., 2016). Safety from the role of the police, as the police significantly prevent crime (Pourkiyani & Farahbakhsh, 2015). Safety from terrorism and the threat of war (Chen, Qiao & Liu, 2009).

#### **Tourism Policy**

policy linked to the needs of the state and the exercise of political power, Received direct or indirect government support. Apply as a guide, Requirements that concern citizens are the process of putting certain principles or concepts into practice now and in the future (Ward et al., 2016). Tourism is one of the main directions in economic development, Tourism generates a lot of income, and reduces unemployment. The government has a policy to promote tourism, Increase good tourism potential, develop tourist attractions, accommodations, and tourist attractions to attract more tourists to travel (Seturi, 2018). Tourism development policies can create systematic changes in tourism development.

The policy has a positive impact on the number of tourists from mainland China, Hong Kong and Macau on the rise (Liu & Lee, 2022). The impact of tourism development policies can be seen in the number of tourists, average length of stay, Average hotel occupancy rate. Contribution of the tourism sector to GDP, total tourism expenditures, and percentage increases in the creative economy, and tourism sector participation (Wulandari & Afriyanni, 2021).

### **Tourism Infrastructure**

Infrastructure is important for tourism as a system and basic services, divided into two types: (1) hard infrastructure such as highways, rail networks, ports, airports, as well as energy transportation systems and (2) soft infrastructure, such as legal and regulatory systems or information systems related to data movement, infrastructure necessary to achieve certain policy goals (Trin Aiyara, 2017). Infrastructure development to meet civilized standards. In addition to benefiting the local population, it also promotes the development of the country's tourism industry to have more potential (Nataya Ket Somboon and Vantana Naowwan, 2019). Tourists feel safe. When serviced in a quality hotel or accommodation, Reasonable price, There is an information technology system that can be connected quickly, Tourist attractions have public transportation such as quality buses or taxis (LATIFF & IMM, 2015). Investment in tourism infrastructure development, Transportation and communications, hotel and restaurant industry, and recreational facilities. It can create attractive destinations and services, having a strong positive influence on Vietnam's tourism (Nguyen, 2021). And if the infrastructure and facilities are insufficient, As well as environmental degradation, access potential to tourist attractions is moderate to low, It will not attract tourists even if the attraction, It will be beautiful and interesting (Sugiama & Tirani, 2022).

### **Public Participation**

Community involvement, especially decision-making, Communities have significant levels of power and influence on their activities (Burns, Heywood, Taylor, Wilde & Wilson, 2004). Members of the community contribute to projects or activities to solve their problems, ideas are proposed, Participation in decision-making and sharing responsibility to make one's life better, under respect, Empowerment and Collaborative Learning (Bretty, 2013). Sharing ideas to make decisions on issues affecting people in the community, Guidance to build in-depth knowledge and stakeholder capacity to share ideas (Stone & Stone, 2011). Tourists come to tourist attractions in large numbers, affecting the income of people and businesses in the community, economically positive. But on the other hand, tourism negatively affects tourist attractions, The society and culture of the community has changed, Reducing such impacts requires the cooperation of community members to manage and solve problems (Salee, Rasoolimanesh & Kusumo, 2022). Public participation in the planning and decision-making process is an important principle in ensuring greater transparency in the operation of tourist attractions (Rijal, 2023). And public participation assessment helps communities recognize the positive and negative impacts of tourism and can adjust or correct impacts more quickly (Riyanto et al., 2023).

### **Destination Management**

Destination management is the process of controlling, supervising, Work to make tourist attractions accommodating tourists without problems, obstacle. Destination management has 3

components: (1) sustainable tourism management (2) Managing tourist education and awareness, Area staff, entrepreneurs and local communities and (3) Socio-economic management from public participation, opportunities for people or communities to participate (Department of Tourism, Ministry of Tourism and Sports, 2017). Organizing tourist attraction activities with community stakeholder participation is an attempt to decide the implementation of tourism as an economic activity (Pulido-Fernandez & Merinero-Rodriguez, 2018). Coordination of local and tourism-related businesses to develop tourism successfully. by planning, application of activities, Destination management contributes to attracting tourists (Tanrisevdi, Ozdogan, Acar & Kilicdere, 2021). If inefficient destination management results in a direct relationship with security, Growth in the number of internet users and related to the tourism industry (Aghdaie & Katebi, 2016). tourism development, Attraction management and destination information management are used to guide visitors, Providing information to tourists helps tourists ensure the safety of tourist attractions (Muhammad & Usman, 2016).

## Research Methodology

### Quantitative Research

The sample was Chiang Mai tourists who agreed to participate in the research. The sample size is based on the research methodology used in the study, i.e. Structural Equation Modeling (SEM). Grace (2008) identified the number of samples suitable for using 20 times the multivariate analysis statistics of the study variables. This study included 16 observational variables. The sample was equal to 320 people. Acquisition of samples from multi-stage randomization (1) Randomly select 1 district in Chiang Mai with simple randomization (2) Randomly select 8 hotels in the randomly selected districts and (3) collect data on 40 Chiang Mai tourists staying in each of the 8 hotels.

The research instrument is 1 questionnaire consisting of 2 parts: 1) 5-question personal data questionnaire and 2) questionnaire on tourism policy, tourism infrastructure, public participation, destination management and tourist safety, Chiang Mai, a total of 64 questions.

Instrument quality check consists of (1) content validity by means of Index of Item -Objective Congruence (IOC) with IOC value between 0.60-1.00; and (2) reliability as well. Cronbach's Alpha Coefficiency Method The total value was .971 and the confidence of each side of the questionnaire, as follows:

Aspects	Sentiment
Tourism Policy	0.880
Tourism Infrastructure	0.891
Public Participation	0.927
Destination Management	0.895
Tourist Safety	0.899

Data Collection: The researcher proceeded to collect data, as follows:

1. Coordinate with the managers of all 8 randomly selected hotels to clarify research objectives Expected benefits and protection of the rights of the sample. Courtesy of collecting information with travelers staying in hotels between February – May 2024, 40 people per place.

2. Upon delivery courtesy 1) Approval document from the Human Research Ethics Committee of Suan Sunandha Rajabhat University and 3) volunteer consent forms to the managers of the 8 hotels. 40 copies each

3. Get the questionnaire back. Check the integrity of every questionnaire and use the complete questionnaire for further analysis.

**Data Analysis**

Data analysis as follows: (1) Descriptive statistics: To describe individual data of all 320 studied samples and to describe the scale of the 16 observable variables with frequency (f), percentage value (%), average ( $\bar{X}$ ), standard deviation (S.D.) of information and (2) Statistics analyze structural equation models (SEM) to create structural equation models. Test the relationship between latent variables and observers, and the findings between latent variables studied.

**Findings**

Present the research results to answer the 3 objectives as follows:

1. The level of tourism policy, tourism infrastructure, public participation, destination management and tourist safety in Chiang Mai is high. It was found that tourism policy has the highest average of 1, followed by tourism infrastructure, tourist safety in Chiang Mai, public participation and destination management respectively, according to Table 1.

**Table 1** Average, standard deviation, Interpretation and sequence of factors studied

<b>Factors Studied</b>	$\bar{X}$	<b>SD.</b>	<b>Interpret the results</b>	<b>Order</b>
Tourism Policy	4.02	0.55	High	1
Tourism Infrastructure	3.98	0.55	High	2
Public Participation	3.82	0.41	High	4
Destination Management	3.78	0.43	High	5
Tourist Safety, Chiang Mai	3.87	0.44	High	3

2. Influence of factors of tourism policy, tourism infrastructure, public participation, destination management towards the safety of tourists in Chiang Mai. By analyzing structural equations, the researcher presents them sequentially, as follows:

2.1 The results of the analysis of the relationship structure model are hypothetically modeled.

2.2 Analysis of the relationship structure model as an alternative model.

2.3 **Comparison** results of hypothesis-based and alternative models.

2.4 Hypothesis test results.

They are presented in the following order:

**2.1 The results of the analysis of the relationship structure model are hypothetically modeled.**

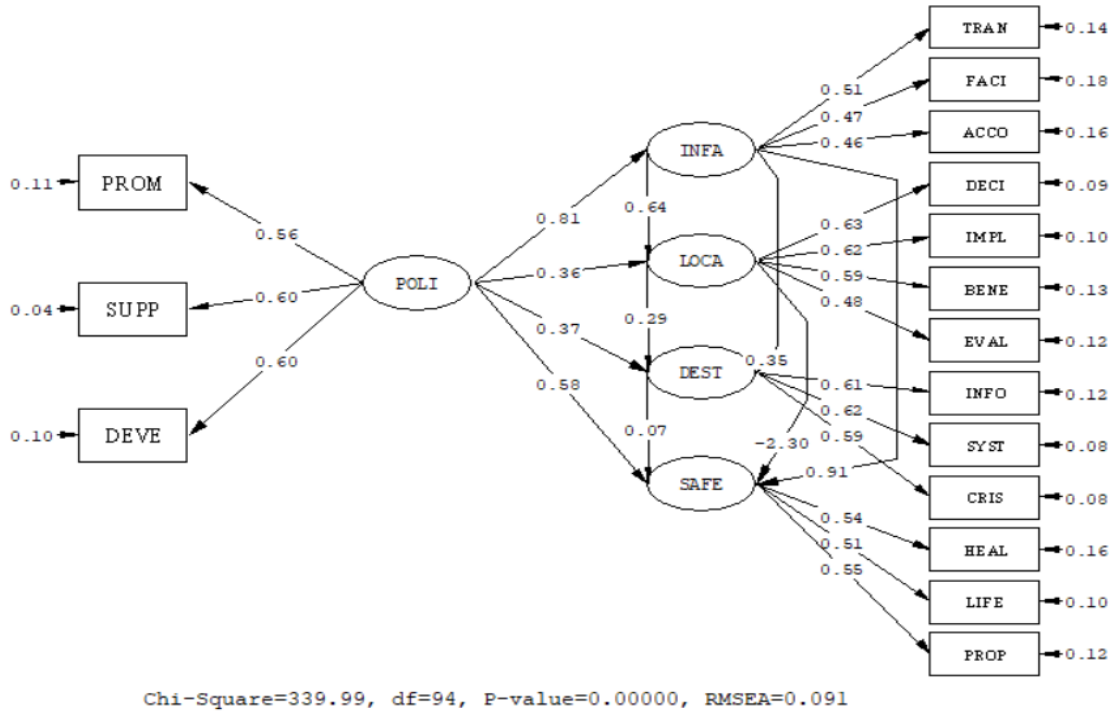
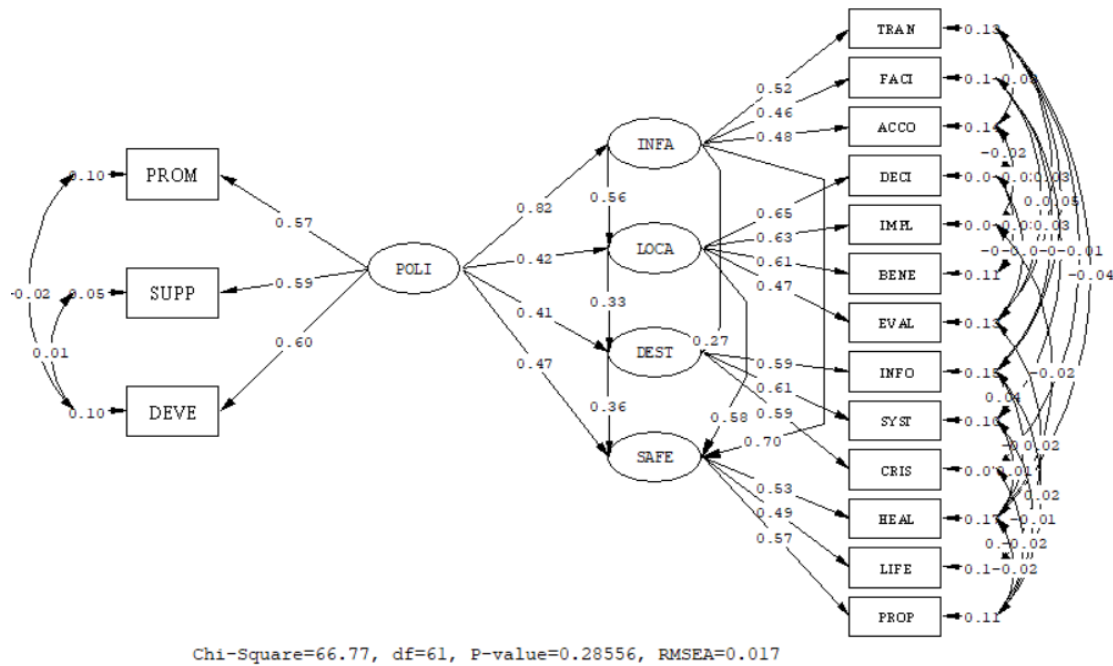

**Figure 1** Hypothetical model

From Figure 1, when considering the hypothesis-based model that the researcher has developed from the relevant concepts and theories, there is no harmonization with the empirical data. Based on the calculated statistics, they are: Chi-square = 339.99, df = 94, p-value = 0.0000, GFI = 0.88, AGFI = 0.83, RMR= 0.013 , RMSEA = 0.091, CFI = 0.99 and CN= 123.29, some key statistics have not met the required criteria.

The researcher adjusted the model by considering the recommendations for adjusting parameters in the model with Model Modification Indices (MI). Then adjust the parameters by agreeing to relax the preliminary agreement so that the tolerances can be correlated. Until the harmonization index values are consistent with the empirical data, an alternative model is obtained. The calculated statistics are Chi-square. = 66.77, df = 61, p-value = 0.28556, GFI = 0.97, AGFI = 0.94, RMR= 0.007, RMSEA = 0.017, CFI = 1.00 and CN = 452.12 Therefore, it can be concluded that structural equation model models are suitable, Harmonize with empirical data Alternative models as shown in Figure 2.

**2.2 The results of the analysis of the relationship structure model as an alternative model.**



**Figure 2** Alternative relationship structure model

**2.3 Results of comparing models based on research hypotheses with alternative models**

Presenting the results of comparing hypothetical and alternative models to demonstrate that alternative models are more suitable and can be leveraged by checking straightness Structurally by examining the harmony between hypothetical and empirical forms and alternative forms and empirical data. It is based on the statistics measuring the level of harmony and the harmonization index, Table 2.

**Table 2** Results of comparison of research hypothesis-based models with alternative models

LIST	STATISTICS	HYPOTHETICAL MODEL	ALTERNATIVE MODELS	INTERPRETATION
1.	Chi-square ( $\chi^2$ )	339.99	66.77	
	* Low near 0			
	* Equal df	94	61	
Relative Chi-square	Quotient( $\chi^2$ /df) < 2.00	3.62	1.09	SUITABLE
2.	GFI > 0.90	0.88	0.97	SUITABLE
3.	AGFI > 0.90	0.83	0.94	SUITABLE
4.	RMR Approach 0.00	0.013	0.007	SUITABLE
5.	< 0.05	0.091	0.017	SUITABLE
RMSEA				

6. CFI	*0.00-1.00	0.99	1.00	SUITABLE
7. CN	> 200	123.29	425.12	SUITABLE

#### 4.4 Hypothesis test results

Based on the research hypotheses that defined four hypotheses, it was found that:

4.4.1 Tourism Policy had a statistically significant influence on tourist safety in Chiang Mai at a level of 0.01. The overall influence value of 0.87 is in line with the assumptions.

4.4.2 Tourism infrastructure had a statistically significant influence on tourist safety in Chiang Mai at a level of 0.01. The overall influence value of 0.86, it is in line with the assumptions.

4.4.3 Public participation had a statistically significant influence on tourist safety in Chiang Mai at a level of 0.01. The overall influence value of 0.70 is based on assumptions.

4.4.4 Destination management had a statistically significant influence on tourist safety in Chiang Mai at a level of 0.05. The overall influence value of 0.36 is in line with the assumptions.

3. Guidelines for promoting tourist safety in Chiang Mai include:

3.1 The government has put in place concrete measures to prevent, care and assist tourists to create tourist safety.

3.2 The government and private sectors encourage people in tourist communities to take part in the care, help tourists.

3.3 Adequate management of tourist information that is up-to-date for tourists, suitable

3.4 Tourist attractions have security systems and procedures in place when there is an incident or emergency situation with tourists.

3.5 Public transport operators pay attention to quality, tourist safety standards and care.

#### Discussion

The results of the hypothesis test revealed that the four latent variables consisted of: (1) tourism policy (2) tourism infrastructure (3) public participation and (4) destination management, details are as follows:

1. Tourism policy has a statistically significant influence on the safety of Chiang Mai tourists, according to hypotheses. Discuss how the government's tourism policy affects the safety of tourists from the determination of the promotion direction, Support, Helping travelers travel safely and happily. Foris (2016) study found that tourism policy involves investment in tourism infrastructure. Defining the system and managing it will ensure the safety of tourists. The Organization for Economic Cooperation and Development (2017) states that one of the roles of tourism policy is to promote tourism development and create added value. High-quality tourism management Taking into account tourist safety, sustainable management of natural and cultural resources. Using tourism as a mechanism for inclusive growth to create quality jobs, business opportunities and regional development, mitigating negative impacts on local communities and tourists, Better distribute benefits to everyone and space.

Shchokin et al. (2023) study found that a lack of comprehensive basic knowledge about effective law enforcement affects crimes committed against tourism. and create insecurity for tourists, Preventive policies, reducing the impact of crime on hospitality and tourism in Europe. Badzagua & Badzagua (2015) stated that tourism promotion and development policies, led to an increase in the number of tourists. As a result, crimes against tourists and tourists themselves are increasing. And Srisawat, Zhang, Sukpatch, & Wichitphongsa (2023) study found that Thailand's tourism policy after the COVID-19 pandemic focused on improving accommodation quality. Setting hygiene standards and networking. It affects the safety of tourists while promoting sustainable tourism. Reduce negative impacts on communities

2. Tourism infrastructure has a statistically significant influence on the safety of Chiang Mai tourists, according to the hypothesis. Discuss whether tourists contribute to the use of transportation services, Accommodation Facilities & Utilities, Infrastructure therefore compromises the safety of tourists. Ginting & Sasmita (2018) stated that infrastructure and facilities such as public transport, accommodation, parking place, Bathrooms, cleanliness of the premises and souvenir shops, etc. These infrastructures support the safety of tourists. Milenkovski, Gjorgievski & According to Nakovski (2020), traffic infrastructure is a major attraction factor influencing tourists' choice of destination. The transportation infrastructure of tourist attractions has resulted in reducing the number of accidents and ensuring the safety of tourists. Kim, Guo & Wan (2021) study found that destination features include infrastructure, environment, Unethical business practices and unexpected events have a strong influence on emotions. And tourist safety for Mazrekaj (2020) study found that investment in road infrastructure affects tourism. Due to shortage of roads or the condition of existing roads is not good enough. This will cause low levels of road safety to affect tourist safety. Developed tourism must be preceded by developed road infrastructure as well. And Chin, Ming & Abang Abd (2022) study found that tourist attraction infrastructure is important for tourist safety and competitiveness of rural tourist destinations.

### **3. Public Participation**

Tourism plays a role in bringing revenue into the community, Improving tourism system and tourism management to meet the needs of tourists. Part of tourism impacts the community, Therefore, it is necessary to encourage people in the community to participate in tourism management, Tourism Resource Management and tourist safety. Zou & Yu (2022) study found that local public participation in decision-making, empowerment, sharing knowledge and community knowledge about tourism contributes to tourism safety and sustainability of rural tourism. Chan, Marzuki & Mohtar (2021) study found that local public participation is important in ensuring the safety of Malaysia's eco-tourism tourists. Thetsane (2019) study It was found that people in the community want to participate in the formulation of tourism policies in order to have policies that meet the needs of stakeholders. In addition to that, the public wants to be part of the tourism development decision to ensure that the community is involved in taking care of tourists. Arisukwu et al. (2020) study found that the absence of social infrastructure lack of local public participation, Inadequate police and lack of government support have resulted in an increase in crime and theft cases against tourists. And

Bhandari (2022) reviewed the literature and found that public participation reduces crime, Fraudulent merchants and business operators in tourist destinations.

#### **2.4 destination management (destination management)**

Creative Attraction Places, Activities, Service and care that is in line with the needs of tourists for tourists to return for repeat trips. destination management. Therefore, it is important and is a factor that affects tourist safety. Terrah, Wildes & Mistry (2020) study found that tourists visiting Turkey expect themselves to be safe. But there is a security gap for tourists regarding destination management. From public transport, accommodation, facilities, convenience of tourist attractions, This diminishes confidence in the safety of tourists and it affects the return of tourism. Otegui-Carles, Araújo-Vila & Fraiz-Brea (2022) found that solo travel among women tourists poses a risk of insecurity. If the tourist attraction does not have security arrangements, such as not installing CCTV cameras or not having enough CCTV cameras. Nagaj & Zuromskaite (2020) study found that higher quality of tourist services also contributes to higher tourist safety. Ding & Wu (2022) study found that tourists' safety perceptions significantly affect the image of tourist attractions. Destination Management to ensure security, Tourists will be satisfied and willing to come back for more. And Owiyo & Mulwa (2018) study found that safety and security are positively correlated with destination management and attraction for repeat travelers In Kenya west.

#### **Suggestion**

Tourists travel to places they are not familiar with or want new experiences from travel destinations. Tourists are therefore strangers to communities and tourist attractions. Differences in language, culture, conduct and behavior are what people in communities and tourist attractions will see on a regular basis. These actions are partly to create insecurity for tourists. However, the creation of tourist safety is the responsibility of all stakeholders of the tourist attraction and all sectors, including the government, private sector and the public sector, must cooperate in prevention. Care and assistance to keep tourists safe while traveling.

#### **Reference**

- Aghdaie, S. F. A. & Katebi, M. (2016). (2016). Analyzing the Role of Information Technology (IT) and Security in Tourism Industry. **International Review of Management and Business Research**, 5(3), 1241-1255.
- Arisukwu, O., Igbolekwu, C., Oye, J., Oyeyipo, E., Asamu, F., Rasak, B., & Oyekola, I. (2020). Community participation in crime prevention and control in rural Nigeria. **Heliyon**, 6, 1-7.
- Badzagua, M., & Badzagua, M. (2015). Significance of Criminological Research in Tourism Development. **European Scientific Journal**, April, 150-152.
- Bank of Thailand. (2022). **Unlock travel with a bang Fueling the Thai economy**. Retrieved February 27, 2023 from <https://www.bot.or.th/Thai/ResearchAndPublications>
- Bhandari, L. (2022). Approaches to Local Community Participation in Tourism Development. **Journal of Tourism & Adventure**, 5(1), 44-61.
- Bretty, E. A. (2013). Participation and accountability in development management. **The Journal of Development Studies**, 2, 57-68.

- Burns, D., Heywood, F., Taylor, M., Wilde, P., & Wilson, M. (2004). **Making community participation meaningful A handbook for development and assessment**. Great Britain: The Policy Press.
- Caldeira, A. M., Seabra, C., & AlAshry, M. S. (2022). Contrasting the COVID-19 Effects on Tourism Safety Perceptions and Coping Behavior among Young People during Two Pandemic Waves: Evidence from Egypt. *Sustainability*, 14 (7492), 1-16.
- Chan, J. K. L., Marzuki, K. M., & Mohtar, T. M. (2021). Local Community Participation and Responsible Tourism Practices in Ecotourism Destination: A Case of Lower Kinabatangan, Sabah. *Sustainability*, 13, 1-18.
- Chen, N., Qiao, G. H., & Liu, L. (2009). Tourism association studies risk perception and outbound tourists travel preferences -Tourists in Beijing. *Geography*, 6, 97–102.
- Chiang Mai Tourism Office. (2018). **Tourist statistics in Chiang Mai**. Retrieved January 18, 2023, from [https://chiangmai.mots.go.th/more\\_news.php?cid=49](https://chiangmai.mots.go.th/more_news.php?cid=49)
- Chin, C. H., Ming, W. W. P., & Abang Abd, D. Z. B. (2022). Effects of destination appeal and tourism infrastructure on rural tourism destination competitiveness and revisit intention: A study in Bario Kelabit Highland. *Pakistan Journal of Commerce and Social Sciences*, 16(3), 366-386.
- Darunee Meksuwan. (2023). **Chiang Mai has set up a tourist assistance center to support the high season**. Retrieved January 12, 2024. from <https://radiochiangmai.prd.go.th/th/content/category/detail/id/57/iid/220626>
- Department of Tourism, Ministry of Tourism and Sports. (2017). **Creative Attraction Management Handbook**. Bangkok: Ministry of Tourism and Sports.
- Ding, G., & Wu, J. (2022). Influence of Tourism Safety Perception on Destination Image: A Case Study of Xinjiang, China. *Sustainability*, 14, 1-21.
- Foris, D. (2016). Tourism Policies and Strategies: Vital in the Actual Security Constrains Context. *Universal Journal of Management*, 4(3), 108-112.
- Ginting, N., & Sasmita, A. (2018). Developing tourism facility based on geotourism in Silalahi village, Geopark Toba Caldera. *Earth and Environment Science*, 126(2018), 1-10.
- Gossling, S., Scott, D., & Hall, C. M. (2020). Pandemics, tourism and global change: a rapid assessment of COVID-19. *Journal of Sustainable Tourism*, 29(1), 1–20.
- Grace, J. B. (2008). Structural Equation Modeling for Observational Studies. *Journal of Wildlife Management*, 72(1), 14-22.
- Kaszas, N., & Keller, K. (2022). The Emergence of Safety and Security in the Tourism Strategies of EU Member States. *GeoJournal of Tourism and Geosites*, 45(4), 1717-1725.
- Kim, J-H., Guo, J., & Wan, Y. (2021). Tourists' negative emotions: antecedents and consequences. *Current Issues in Tourism*, 25(12), 1-13.
- Latiff, K., & Imm, NG, S. (2015). The Impact of Tourism Service Quality on Satisfaction. *International Journal of Economics and Management*, 9 (S), 67 – 94.
- Liu, Y. S., & Lee, L. (2022). Policy and Political Effects on Tourism Development. *Tourism Analysis*, 27, 437–445.
- Ma, H., Chiu, Y-H., Tian, X., Zhang, J., & Guo, Q. (2020). Safety or Travel: Which Is More Important? The Impact of Disaster Events on Tourism. *Sustainability*, 12, 1-12.

- Mawby, R. I., Tecau, A. I., Constantin, C. P., Chitu, L. B., & Tescasiu, B. (2016). Addressing the Security Concerns of Locals and Visitors for the Sustainable Development of Tourist Destinations. **Sustainability**, 8, 2-12.
- Mazrekaj, R. (2020). Impact of Road Infrastructure on Tourism Development in Kosovo, **International Journal of Management**, 11 (4), 466- 474.
- Milenkovski, A., Gjorgievski, M., & Nakovski, D. (2020). The Impact of the Traffic Infrastructure on the Tourist Destination. **UTMS Journal of Economics**, 11(1), 43–47.
- Ministry of Tourism and Sports. (2023). **Tourism Statistics 2022**. Retrieved April 17, 2023 from <https://www.mots.go.th/news/category/655>
- Muhammad, A. S., & Usman, G. (2016). Destination Information Management for Tourist. **Computer Science and Telecommunications**, 6-29, 81-88.
- Nagaj, R., & Zuromskaite, B. (2020). Security Measures as a Factor in the Competitiveness of Accommodation Facilities. **Journal of Risk Financial Management**, 13(99), 1-16.
- Nataya Ket Somboon and Vantana Naowwan. (2019). Tourism potential for tourism village development Nong Sarung Village, Krasaeng Subdistrict, Bang Sai District, Ayutthaya Province. **Association of Private Higher Education Institutions of Thailand Patronage of the King HRH Princess Maha Chakri Sirindhorn**, 25(1), 81-93.
- Nguyen, Q. H. (2021). Impact of Investment in Tourism Infrastructure Development on Attracting International Visitors: A Nonlinear Panel ARDL Approach Using Vietnam's Data. **Economies**, 9, 1-19.
- Online Manager. (2024). **The Chiangmai-Pai van was involved in an accident. 2nd dead foreign officer - Dozens more were injured**. Retrieved January 12, 2024 from <https://mgronline.com/local/detail/9660000101152>
- Otegui-Carles, A., Araújo-Vila, N., & Fraiz-Brea, J. A. (2022). Solo Travel Research and Its Gender Perspective: A Critical Bibliometric Review. **Tourism and Hospitality**, 3, 733–751.
- Owiyo, I., & Mulwa, J. M. (2018). Safety and Security in Tourism Destinations: Its moderating role in the Destination Competitiveness Determinants and Destination Competitiveness Nexus in Western Kenya Circuit. **International Journal of Research in Management & Business Studies (IJRMBS)**, 5(3), 30-33.
- Payam, M. M. (2016). Tourists' Security: The Need for Tourism Police in Bosnia and Herzegovina. **British Journal of Economics, Management & Trade**, 12(1), 1-9.
- Pourkiyani, M., & Farahbakhsh, A. (2015). Survey of Effective Factors on Sense of Security and Attracting Foreign Tourists. **Management and Administrative Sciences Review**, 4(1), 101-111.
- Pulido-Fernandez, J. I., & Merinero-Rodriguez, F. (2018). Destinations' relational dynamic and tourism development. **Journal of Destination Marketing & Management**, 7, 140-152.
- Radovic, V., & Arabska, K. (2016). Why should security aspects be more seriously considered in development of Serbian tourism industry?. **TIM Acta**, 10(2016), 71-80.

- Rijal, S. (2023). The Importance of Community Involvement in Public Management Planning and Decision-Making Processes. **Journal of Contemporary Administration and Management (ADMAN)**, 1(2), 84-92.
- Riyanto, Iqbal, M., Supriono, Fahmi, M. R. A., & Yuliaj, E. S. (2023). The effect of community involvement and perceived impact on residents' overall well-being: Evidence in Malang marine tourism. **Cogent Business & Management**, 10, 1-20.
- Salee, A., Rasoolimanesh, S. M., & Kusumo, C. M. L. (2022). Tourism Impacts on Destinations: Insights from a Systematic Review of Literature. **APJIHT**, 11(1), 121–148.
- Seturi, M. (2018). **About the Importance of Tourism Promotion Policy (Georgian Case)**. PROCEEDINGS, 2018 International Scientific Symposium “Economics, Business & Finance”, 76-81.
- Shchokin, R., Maziychuk, V., Mykhailyk, O., Kolomiets, A., Akifzade, S., & Tymoshenko, Y. (2023). The Impact of the Crime Rate on the Hospitality and Tourism Industry in the EU Countries. **GeoJournal of Tourism and Geosites**, 46(1), 135-147.
- Srisawat, P., Zhang, W., Sukpatch, K., & Wichitphongsa, W. (2023). Tourist Behavior and Sustainable Tourism Policy Planning in the COVID-19 Era: Insights from Thailand. **Sustainability**, 15 (5724), 1-21.
- Stone, L.S., & Stone, T.M. (2011). Community-based tourism enterprises: challenges and prospects for community participation; Khama Rhino Sanctuary Trust, Botswana. **Journal of Sustainable Tourism**, 19(1), 97-114.
- Sugiama, A. G., & Tirani. N. (2022). The Identification of Infrastructure, Accessibility, Environment, and Physical Tourism Attraction Resources: Cibereum Lake Case. **Advances in Engineering Research**, 207, 1-6.
- Tan, C. H., Chong, X. W., & Ho, S. B. (2017). Significant of safety and security issues on tourism industry in Malaysia. **Science International (Lahore)**, 29(2), 471-475.
- Tanrisevdi, A., Ozdogan, O. N., Acar, V., & Kilicdere, S. (2021). Destination Management: Right or Wrong Measures. **Journal of Global Business Insights**, 6 (1), 1-21.
- Terrah, A., Wildes, V., & Mistry, T. G. (2020). Antalya's tourist security: A gap analysis of expectations vs perceptions. **Journal of Global Business Insights**, 5(2), 150-168.
- The Organization for Economic Cooperation and Development. (2017). **Policy Statement - Tourism Policies for Sustainable and Inclusive Growth**. Paris: OECD.
- Thetsane, R. M. (2019). Local Community Participation in Tourism Development: The Case of Katse Villages in Lesotho. **Athens Journal of Tourism**, 6(2), 123-140.
- Trin Aiyara. (2017). Transport infrastructure and state formation: a proposed trial. **Journal of Social Sciences, Naresuan University**, 13(1), 69-94.
- Vuuren, I. V. (2016). Tourism Safety & Security Risk Factors – A New Model. **Infosum** 06/2016.
- Ward, S, C., Bagley, C., Lumby, J., Hamilton, T., Woods, P., & Roberts, A. (2016). What is ‘policy’ and what is ‘policy response’? An illustrative study of the implementation of the leadership standards for social justice in Scotland. **Education Management, Administration and Leadership**, 44(1), 43-56.

- Wulandari, S. N., & Afriyanni. (2021). Tourism Development Policy and Their Impact on the Regional Economy in the Riau Islands Province. **Jurnal Bina Praja**, 13(2), 293–305.
- Zou, Y., & Yu, Q. (2022). Sense of safety toward tourism destinations: A social constructivist perspective. **Journal of Destination Marketing & Management**, 24, 1-10.